

## Multi Round Over Cutter

Category **CNC**

Cutterhead body in hard wearing aluminum, complete with disposable tungsten carbide knives. Suitable for rounding over the edge of softwood, hardwood and man-made boards on a spindle moulder.

Either raising or lowering the cutterhead on the machine selects different radius.



Hand  
feed



Aluminum  
Body

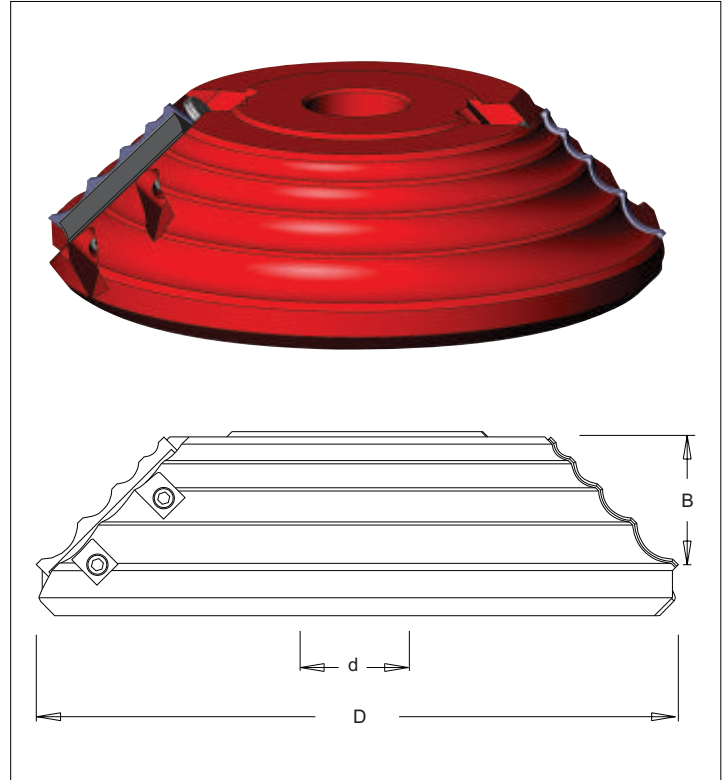

Tool no.	D	d	B	Teeth	R=mm	RPM
K167C140	140mm	1 1/4"	18mm	2	2,3,5	5,400-8,800
K167C180	180mm	1 1/4"	35mm	2	4,6,8,10	4,500-7,500

### Replacement Parts:



T.C. Blade  
3108550  
R=2, 3, 5



Wedge  
1990486  
L=24 mm



Allen Screw  
1930265  
M6x16



Allen Key  
1940035  
S3

**R= 2, 3, 5 mm**

**R= 4, 6, 8, 10 mm**

3108549  
R=4, 6, 8, 10

1990485  
L=48 mm

1930265  
M6x16

1940035  
S3

